



SANDEN

Sanden SD7H15

Semi Super Heavy Duty Compressor Super heavy Duty Compressor



- Heavy Duty 7 piston wobble plate design compressor with magnetic clutch
- 8kW cooling capability with 155cc displacement
- Speed range 700 - 6000 rpm
- Suitable for R134a refrigerant with Sanden SP-10 oil
- Ear mount and direct mount options
- Available in 12 and 24 volt
- Numerous clutch and cylinder head options for Super and Semi Super Heavy Duty application
- Clutch with friction liner and thermal fuse
- Enhanced durability with dust protection

Semi Super Heavy Duty

Super Heavy Duty

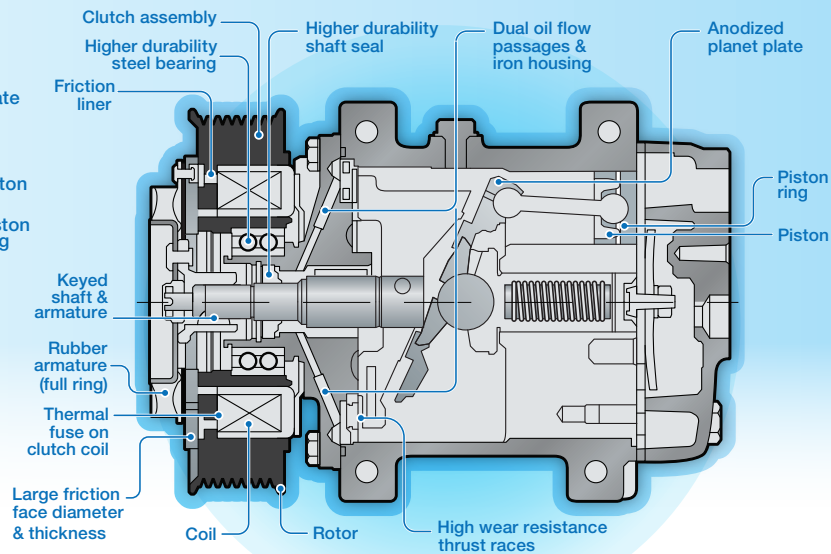
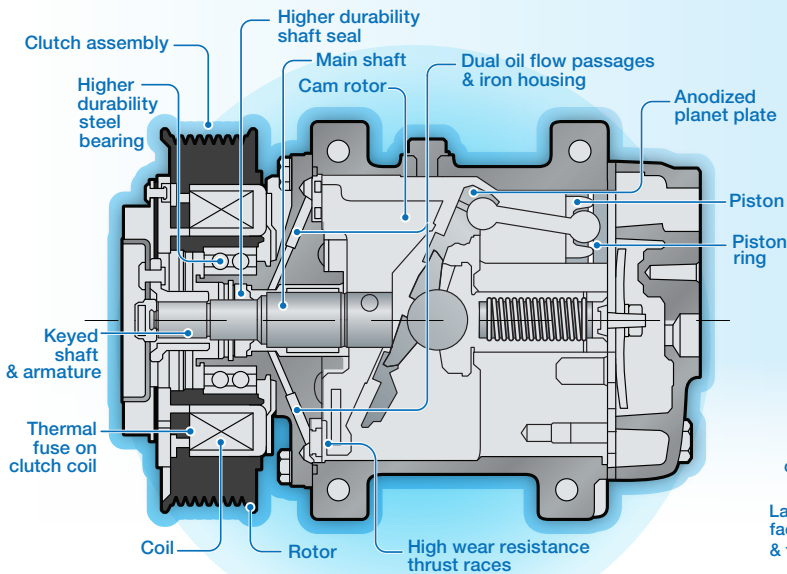

SD7H15 Performance

Pressure Dis/Suc : 1.67(MPa) /
196(kPa)[gauge]
Sub Cool / Super Heat : 0 / 10(K)

